

MagnaPlast Sewer Manhole

*Engineered and Manufactured for every
Sanitary Sewer Gravity Collection System in the World*

Patent Pending# 63/789, 260

Technical Specifications:

- Standard Inside Diameter: 4-feet
- Cylinder Wall Thickness: 0.75" to 1.5" (varies with structure depth)
- Manhole Depth: 4-feet to 20-feet
- Inlet/Outlet Pipe Stub: 8" SDR26
- Manway Entry Diameter: 24"
- Channel Cross-Slope: 2.08% (Inlet to Outlet)
- Mannings N Value: 0.010

Features and Benefits:

- Virgin HDPE Plastic Resin
- Single Piece (monolithic) Assembly
- Lightweight for Easy Transport & Field Installation
- Factory Leak Tested & Certified
- Factory Assembled per the following:
 - Desired Structure Depth (in 0.10 ft increments)
 - 31 different Inlet Combinations
 - Accommodates Cast Iron & Composite Frame and Cover Assemblies
- Easily Field Adjusted Top Elevation using HDPE Spacer Rings & Gaskets
- Custom Field Penetrations easily accomplished
- H-20 Load Rated Design Available
- Impervious to Corrosion (hydrogen sulfide gas & sulfuric acid formation)
- Expected 100-year Continuous Duty Service Life



Manufactured by:



www.houstonpolytank.com

MagnaPlast Sewer Manhole

MANHOLE INTERNAL PLAN VIEW

Manhole Base Plate Assembly

8-inch Inlet Stub (typical)

Channelized Internal Sump

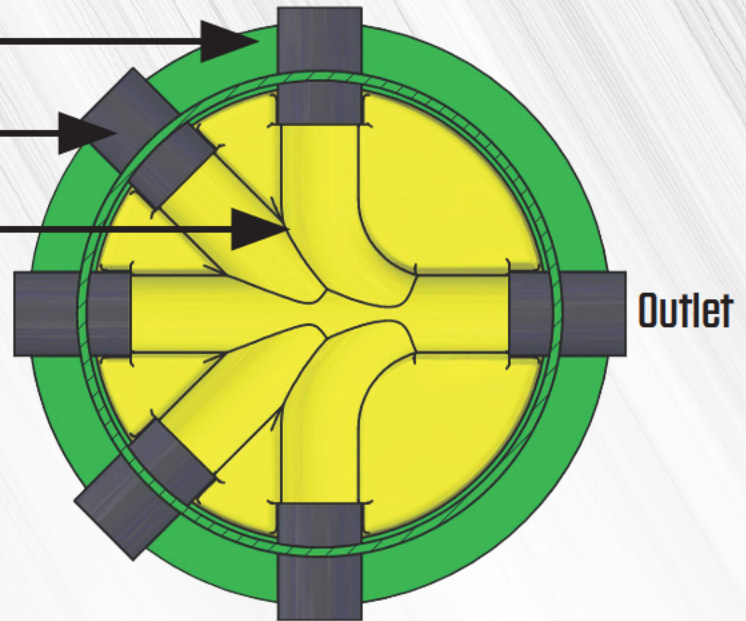

MANHOLE INTERNAL SECTION VIEW

Manhole Frame & Cover Assembly

HDPE Grade Adjustment Ring(s) (typical)

48" ID HDPE Circular Riser Assembly

MagnaPlast provides a 100-year anticipated service life for typical public sanitary sewer utility systems

8-inch Inlet Stub (typical)

Channelized Internal Sump

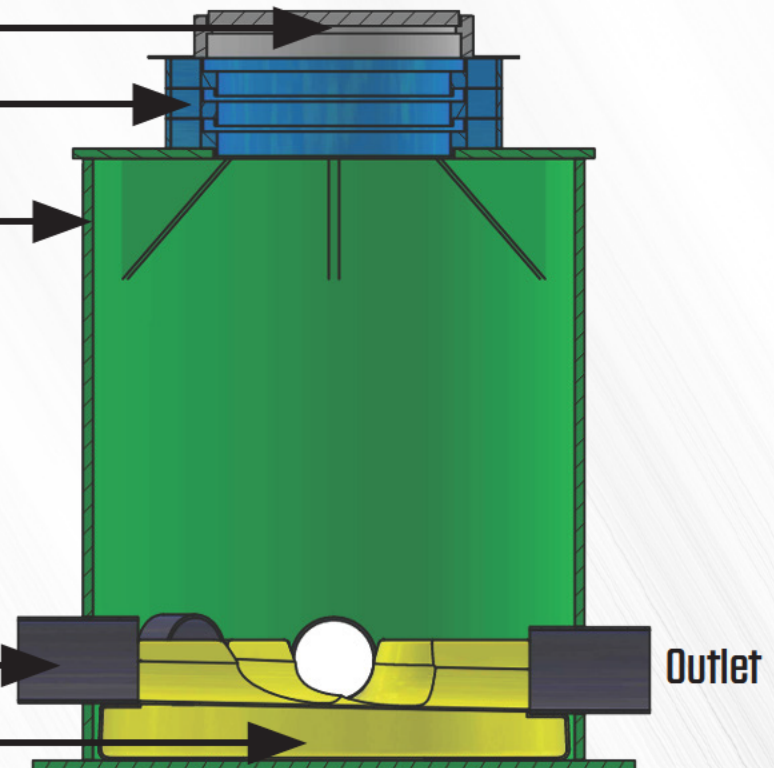

Promoted & Sold in partnership with:



INFRASTRUCTURE DYNAMICS
SUSTAINABLE UTILITIES FOR A BETTER TOMORROW

