



INFRASTRUCTURE DYNAMICS

SUSTAINABLE UTILITIES FOR A BETTER TOMORROW

EveraMOD Wastewater Lift Station

Commercial Series (CS Model)

ENGINEERING SUPPORT!

COMPLETE PACKAGE!

FAST QUOTING!

EASY INSTALLATION!



EveraMOD COMPLETE INSTALLATION

EveraMOD™ from INFRASTRUCTURE DYNAMICS is the pre-engineered, factory-direct pump station solution built for commercial projects. Whether you're serving a strip mall, business park, or residential subdivision, we simplify procurement and speed up delivery — without sacrificing customization.



EVM 48-10 - PACKAGE READY TO SHIP



EVM 60-15 INSTALLED



**STRAIGHT FROM
THE FACTORY
TO YOUR JOB
SITE!!**

**BASIC
PACKAGES
STARTING AT
\$49,900!**

EveraMOD COMPLETE PACKAGE SHIPPED

EveraMOD

Wastewater Lift Station

Why Choose EveraMOD™?

- Manufactured to Project Specifications
- Factory-Direct Pricing
- Delivery in Weeks, not Months
- Fully Assembled — Drop-in Ready
- Made to Order!

EveraMOD™ Basic Equipment Package

- Basic Equipment Package include:
 - Structural Plastic Wetwell w/ Aluminum Access Hatch
 - Duplex Slide Rail Package
 - SCH 80 PVC discharge piping with internal control valves
 - Two (2) wastewater pumps (grinders or solids handling type)
 - Four (4) Level Control Floats
 - NEMA 4X control panel w/ alarm light, horn, & silence button
- Factory Assembled, Leak Tested, and Certified.
- Purchase includes Installation Guide, and O&M Manuals
- Available Upgrade Options:
 - PLC & HMI controller system & Remote Monitoring
 - Analog level transducer
 - External Valve Vault Package
 - Trash Basket with rail system
 - Davit Crane
 - Flow Meter Vault Package
 - Emergency Generator w/ Automatic Transfer Switch

**BASIC
PACKAGES
STARTING AT
\$49,900!**

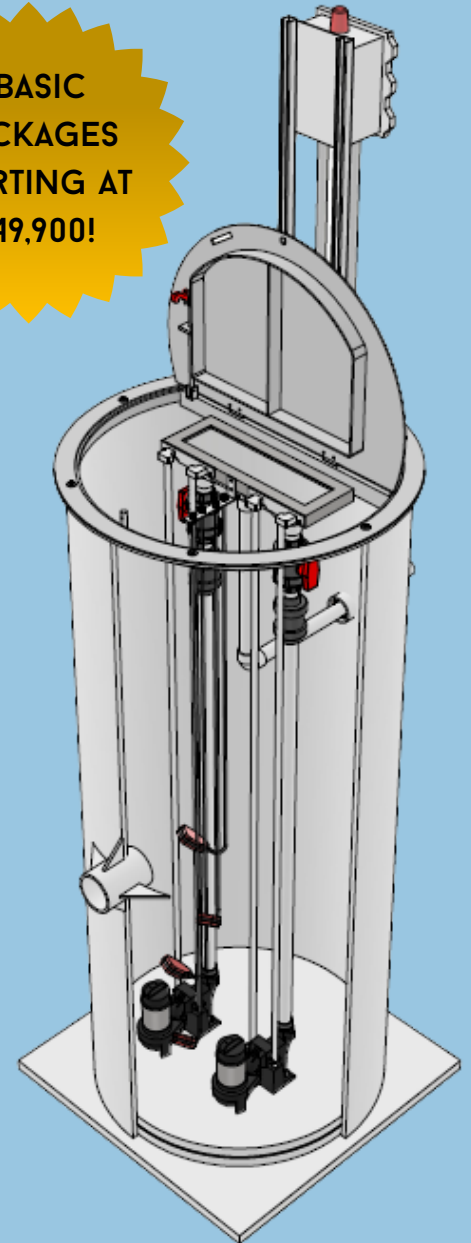

SPEED — SIMPLICITY — EFFICIENCY — AFFORDABILITY

Budget-Minded Pump Station Options for Commercial Projects

Site development engineers, general contractors, and real estate developers — if you need a fast, cost-effective wastewater pump station, the EveraMOD™ Commercial Series delivers.

Designed specifically for budget-conscious projects, EveraMOD CS meets or exceeds local regulatory standards while offering long-term reliability comparable to municipal and industrial-grade systems. Choose a basic equipment package or upgrade to fit your exact project requirements — all while staying on time and on budget.

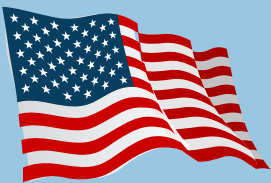

Made in America!

- Diameters: 48" - 60" - 72"
- Depths: up to 15 ft
- Submersible Pumps
- Control Panel & Control Floats
- Made to Order

REQUEST A QUOTE by Email or Phone!

email us: info@infrastructure-dynamics.com

Call Us: 540-200-8684



EveraMOD INSTALLATION

900 University City Blvd PO Box 10056
info@infrastructure-dynamics.com

Blacksburg, Virginia 24062

Ph: 540 200 8684

www.infrastructure-dynamics.com